

eMP Metering Pump

OPERATING INSTRUCTIONS AND MAINTENANCE





ETATRON

AMERICA

SAFETY STANDARDS	3
Symbols used in the manual	3
Warnings and Risks	3
Dosage of hazardous and/or toxic liquids	4
Shipping to the factory for repairs and/or maintenance.....	4
GENERAL REGULATION	5
Proper use of the pump.....	5
Shipping and handling	5
Assembly	5
Dismantlement.....	5
Warranty	5
ANALOGIC DOSING PUMPS eMP	6
Operating principles	6
Technical features	6
Reference Standards.....	6
Overall dimensions	7
Material in contact with the additive.....	7
INSTALLATION	7
Introduction	7
Pump installation	8
Back Pressure and Anti-Syphon Valve	8
Tube connection.....	9
Typical installation.....	9
Accessories	10
OPERATING INSTRUCTIONS	11
eMP PUMP	11
Commands	11
Commands description	11
UNDER-LOAD and OVER-LOAD functions	12
MAINTENANCE	13
Ordinary.....	13
Extraordinary	14
Mechanical Faults.....	14
Electrical Faults	14
Routine	14
TROUBLESHOOTING	16
APPENDIX 1 – PUMP DRAWINGS	17
APPENDIX 2 – EXPLODED VIEWS	18
TUBES INSTALLATION	19

3/8" – 1/2" INJECTION VALVE.....	20
Comprehensive view and features	20
Overall dimensions and characteristics	20
Kit contents	21
Exploded view	21
3/8" – 1/2" FOOT VALVE FILTER	22
Comprehensive view and features	22
Kit contents	23
Exploded view	23

Symbols used in the manual

		
<p>PROHIBITED Precedes information that is inherent to safety. It flags something that is not to be done.</p>	<p>WARNING Precedes a text that is very important for the protection of the health of exposed persons or for the machine itself.</p>	<p>INFORMATION NOTICE Precedes information concerning the use of the equipment.</p>

Warnings and Risks

Carefully read the warnings listed below as they provide important information regarding safe installation, use and maintenance. Store this manual carefully for future reference.

Once the packaging has been removed, check the pump, and if in doubt do not use the pump and consult with qualified personnel. The packaging materials (such as plastic bags, polystyrene, etc..) must not be left within reach of children as they are potential sources of danger.

Before connecting the pump, make sure that the data on the plate corresponds to that of the power distribution network. The nameplate data is shown on the adhesive label attached to the pump.

PLEASE NOTE:

- The equipment is made to the highest quality. Its durability, electrical and mechanical reliability will be enhanced if it is correctly used and undergoes regular maintenance.
- Pump is supplied with grounding power cord and attached plug, to reduce the risk of electrical shock, connect only to a properly grounded receptacle install only on a circuit protected by a ground fault circuit interrupter (GFCI).
- The electrical installation must comply with the rules in force in the country where it is installed. The use of any electrical device requires compliance with some basic rules. In particular:
 - do not touch the equipment with wet or damp hands or feet;
 - do not handle the pump with bare feet
 - do not leave the unit exposed to the elements (rain, sun, etc.). Protect pump chemicals from freezing temperatures;
 - do not allow the pump to be used, serviced or cleaned by children or by people without adequate training and without supervision.



WARNING:

- Any intervention or repair within the equipment must be carried out by qualified and authorized personnel. We disclaim all responsibility as a result of non-observance of this rule.
- This equipment must NOT be used by: children, people with impaired physical, sensory or mental capabilities, inexperienced personnel, unless they are supervised or instructed on the appropriate use of the unit by a person responsible for their safety.
- In case of failure and / or malfunction of the pump, turn it off and do not tamper with it. For any repairs please contact our service centers and request the use of original spare parts. Failure to comply with the above may compromise the safety of the pump.
- If you decide to no longer use an installed pump it is recommended to make it inoperative by disconnecting it from the power supply and emptying the pump body.
- If there are leaks from the hydraulic part of the pump (breakage of seals, valves, pipes), you must stop the operation of the pump, depressurise the discharge pipe and proceed with maintenance using appropriate safety measures (gloves, goggles, overalls, etc.).



- In case of failure and/or malfunction of the pump, turn it off and do not attempt to repair it. For any repairs please contact our after-sales service centers and request the use of original spare parts. Failure to comply with these conditions may compromise the proper operation of the pump.
- In the event of damage to the pump power cable, ask for it to be replaced by our service centers or qualified personnel to prevent risks for the people who use it;

EXPLOSION HAZARD:

- This equipment is not explosion-proof. Do NOT install and do NOT use in an explosive or potentially explosive environment.



Dosage of hazardous and/or toxic liquids

To avoid damage to persons or property arising from contact with hazardous liquids or toxic fumes, in addition to compliance with the instructions contained in this booklet, the following standards should be made well aware of:

- Always wear protective clothing, including gloves and safety goggles, operating as recommended by the manufacturer of the liquid (additive) to be used. (Risk of potential explosions, burns, fire, personal injury or damage)
- Check that the hydraulic part of the pump is not damaged or broken and use the pump only when in perfect condition.
- Use tubes suitable for the liquid and the operating conditions of the plant, for additional protection insert PVC tubes.
- Before you turn off the metering pump you must depressurise the system and neutralise the hydraulic part with a suitable reagent.
- When connecting a pump either to the public water supply or to its own source, you must respect the regulations in force concerning protection of the source i.e. backflow prevention, etc.
- WARNING: Protect the pump and chemicals from the elements (frost, rain, sun etc.).
- It is recommended to install the pump in areas where leakage of liquid product (additive) cannot cause personal injury or property damage.

Shipping to the factory for repairs and/or maintenance



The material to be sent to the factory for maintenance should be disassembled and packed carefully; all the parts in contact with the chemical must be emptied and rinsed to ensure the safety of the operators while transporting and handling the material in the laboratory. In the event of failure to comply with the instructions given, we reserve the right to reject the equipment and to return it at your expense; damage caused by the chemical to the material will be included in the repair estimate.



Proper use of the pump

The pump must only be used for the purpose which it was expressly manufactured, i.e. to dose liquids. Any other use is considered improper and therefore dangerous. The pump is not foreseen for use in any applications not taken into consideration during the design stage. For further clarifications the customer must contact our offices where the user will receive information about the type of the pump in his possession and its correct use. The manufacturer cannot be considered responsible for any damage derived from improper, erroneous and unreasonable use.

Shipping and handling

Shipping must be performed in the same orientation as indicated on the packaging. Shipping using any means, even if delivered free to the customer, is considered at the purchaser's risk. Claims for missing material must be made within 10 days from goods receipt. Claims for defective material must be made within 30 days from goods receipt. Restitution of pumps must be agreed beforehand with authorized personnel or with the authorized distributor.

Assembly

All the pumps we produce are normally supplied fully assembled. For better clarification, consult the appendix at the end of this manual where exploded assembly drawings and views of the pumps are available together with all components and their nomenclature, for the user to have complete details of the pump components. These drawings are indispensable when searching for malfunctioning or defective parts. Other drawings refer to hydraulic parts (pump header and valves) and are shown for the same reasons in the appendix at the end of the booklet.

Dismantlement

To dismantle the pump or before performing pump maintenance, proceed as follows:

- Make sure the pump is electrically deactivated (both poles) by disconnecting the conductors from the power supply using the omnipolar switch which must have a minimum distance of 3mm between its contacts.
- Relieve the pressure in the pump head and the discharge tube in the most adequate way possible (be very careful during this operation).
- Drain the liquid present in the pump head by disassembling and reassembling the pump head using the four fixing screws, tightening torque 180÷200 N*cm (Appendix 1).

Please pay particular attention to this last point and we recommend the user to consult the enclosed drawings and chapter "RISKS" before starting any operations.

Warranty

2 years (normal wear on parts is excluded, i.e.: valves, fittings, piping ring nuts, piping, filter and injection valve). Improper equipment use invalidates the warranty. For warranty contact ETATRON AMERICA.



Operating principles

Dosing pump operation is ensured by a PTFE (teflon®) membrane mounted on the piston of an electromagnet. When the piston of the electromagnet is attracted, pressure is produced in the pump head and liquid is ejected from the discharge valve. Once the electrical impulse has terminated a spring brings the piston back to its original position and liquid is called in through the suction valve. Due to this simple operation of the pump, no lubrication is needed and maintenance is reduced to nearly zero. The materials used to manufacture the pump make it fit for use even with particularly aggressive liquids. The dosing pump is designed for the flow rate of 5.28 GPH with pressure of 101 PSI.

Technical features



- Equipment manufactured according to CE regulation
- Anti acid plastic casing
- Control panel protected by adhesive film resistant to atmospheric agents and UV rays
- Power supply: extended range 90 – 260 Volt 50-60 Hz
- Prewired with 120 V nema 5-15P plug
- IP65 protection level
- Environmental conditions: closed environment, altitude up to 2000 m, ambient temperature from 41°F to 104°F, maximum relative humidity 80% up to a maximum of 88°F (linear decrease down to 50% at 104°F).
- Classification with respect to protection against indirect contacts: CLASS I (the equipment is supplied with an electrical protection conductor).

Reference Standards

The dosing pump is in accordance with the following directives:

- 2006/95/CE: "low tension"
- 2004/108/CE: "electromagnetic compatibility"

Type	Flow rate	Pressure [PSI]	Stroke [imp/1']	Standard power supply	Power adsorbed [W]	Current MAX [A]	Net weight [kg]
	oz/min						
eMP	0,56	145	0 – 180	100 -250 V / 50-60 Hz	19	1,4	3,0

The values listed above are intended to be within a tolerance of +/- 5%. They were obtained by a series of test performed on similar equipments with water at temperature of 68°F.

Overall dimensions

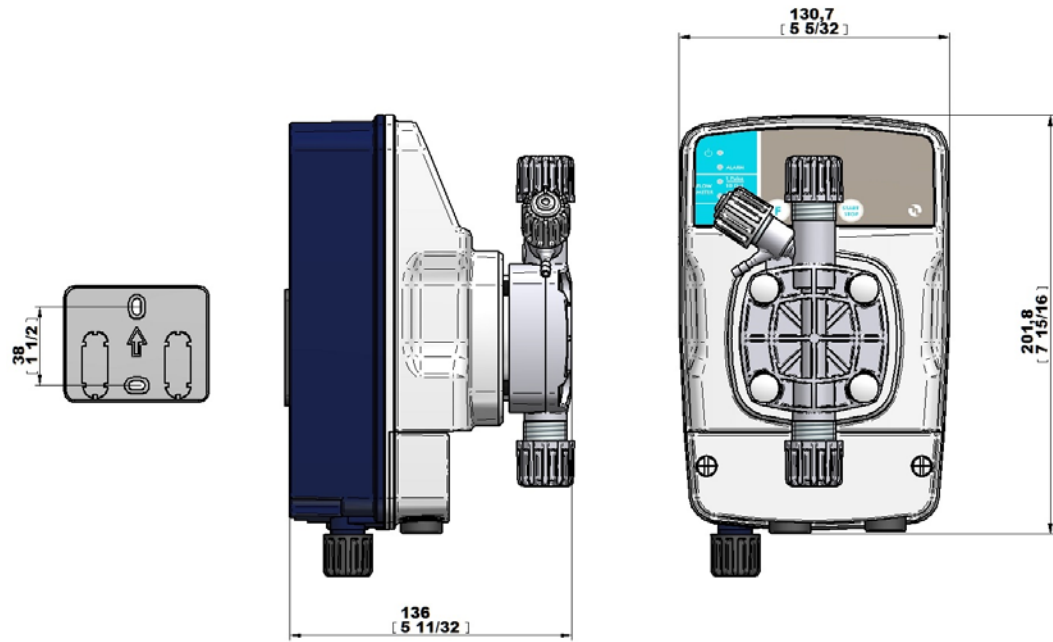

Fig. 1 - Dimensions in mm. Plate for wall mounting.

Material in contact with the additive

In the standard configuration the pumps of the "eOne" series are supplied with the following materials:



Pump Head	Membrane	Seals	Valves	Connections	Tubing	Pump Casing
PVDF	PTFE	TFE/P	CERAMIC TFE/P	PVDF	PE / PVC	PP

INSTALLATION



Introduction

This section describes steps for installing the pump, hoses and wiring. Please read this instruction before starting any activity.

Follow these guidelines when installing the pump:

- Make sure the pump is powered off and any other related equipment before starting any activity.
- In case of any unusual events or warning signs, stop immediately. Start again only when you are absolutely sure that any possible problem has been solved.
- Do not install the pump in hazardous environments such as at risk of fire or explosion.
- Avoid risk of electrical type and or fluid leakage. Never use a damaged or defective pump.

Pump installation

Install the pump away from heat sources, in a dry place and at a maximum ambient temperature of 104°F. The minimum operating temperature of the pump depends on the liquid to be dosed, as the liquid must remain a fluid state.

Locate the pump as shown in fig.2 taking into account that it can be located over or under the liquid level within a maximum difference of 1,5 meters. The injection point must always be located higher than the liquid to be dose.

If the plant being treated operates at atmospheric pressure (free discharge additive) and the additive tank must be placed higher than the injection point (Fig. 2a), check periodically that the injection valve is operating correctly, as excessive wear could cause additive injection by liquid loss (even when the plant is not operating). If the problem persists, insert a correctly calibrated **counter pressure valve C** between the dosing pump and the injection point (Fig. 6).

For liquids that give off aggressive exhalations, do not install the pump over the tank unless the tank is hermetically sealed.

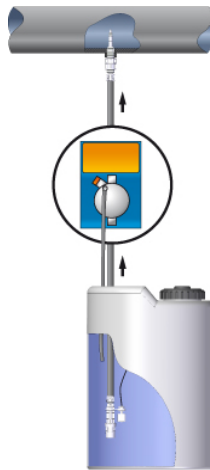

Fig. 2

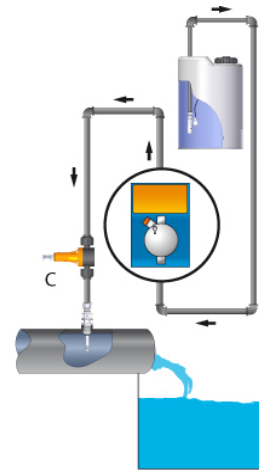

Fig. 3

Back Pressure and Anti-Syphon Valve

Syphoning can occur if you are pumping downhill or into low or no pressure. It is recommended to install a back pressure anti syphoning valve (fig. 3)

The suggested installation is that the pump is to be install higher than the chemical being injected with the injection valve into the main line higher than the pump. If the chemical being injected is higher than the injection point gravity feeding can occur. Its recommended to install a back pressure anti syphoning valve



Tube connection



The discharge nipple will always be at the top side of the pump from where the tube goes to the plant to be treated. The suction nipple will always be at the bottom side of the pump, where the tube will be mounted with the filter that goes to the tank of the liquid to be dosed.

1. Remove the seal from ring nut (2)
2. Insert tube through ring nut (2) and bush (3)
3. Press the hose end (1) onto the conic adapter of the nozzle (4)
4. Place the nozzle (4) onto the nipple (5)
5. Tighten the ring nut (2) onto the nipple (5)

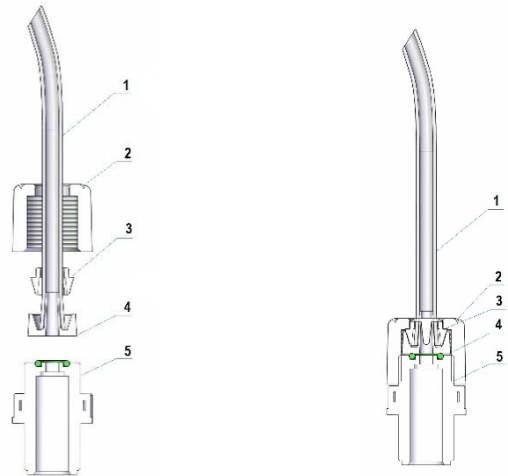

Fig.4 – Tubes connection

To prime the pump: Connect the discharge tube and follow the sequence shown in Figure 5.

- unscrew the manual air bleed knob, the pump has to be turned on;
- keep open the bleed valve B until all the air, inside the tube and inside the pump head, is out;
- close the manual air bleed knob.

In case of difficulty, use a syringe connect to the bleed nipple and extract the air.



To prime the pump use the function button (labeled F) and select the PRIMING option press the start button.

Make sure tube is connected to the discharge valve returning

Priming solution back down to the tank

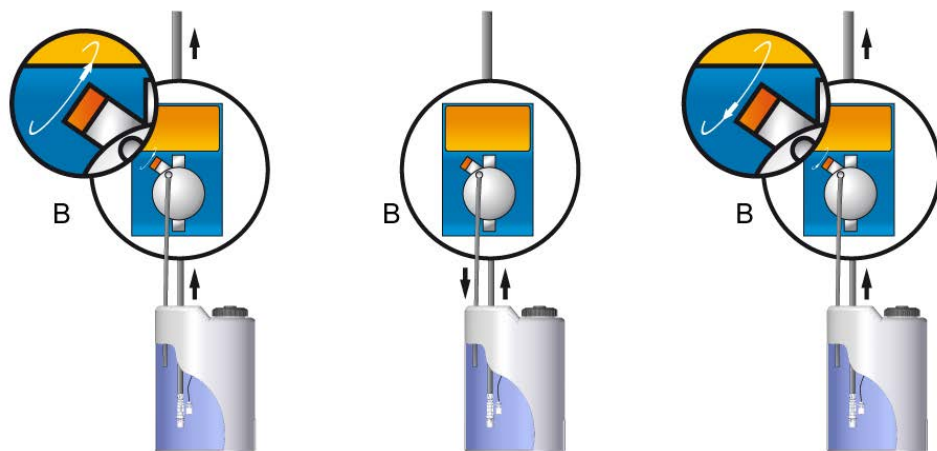

Fig.5 – Priming sequence

Typical installation

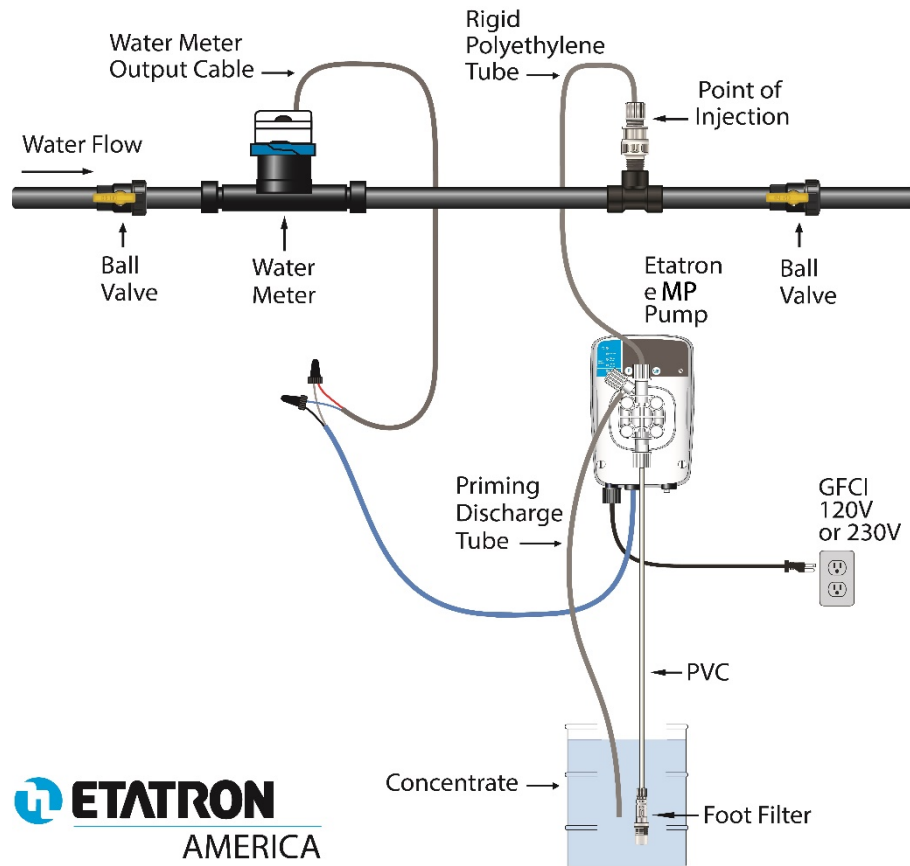

Fig. 6 – Typical installation

Avoid unnecessary curves and narrow on both the discharge and suction pipes. Screw the injection valve into ½ BSP fitting into the main line, in the most suitable location for the injection of the product to be dosed. This fitting for the main line is not supplied. Screw the injection valve on the nipple using PTFE tape as a seal (Figure 8). Connect the tube to the conical adapter of the injection valve and secure with the hose ring nut (see figure 4 for connection instructions). The injection valve is also a no-return valve.



Two types of tubing are supplied, clear PVC and rigid PE. It is critical that the PVC be used only for the suction tube and manual air bleed valve. The rigid PE tubing is connected on the discharge side of the pump to the injection valve.

Conical connection ½" BSP

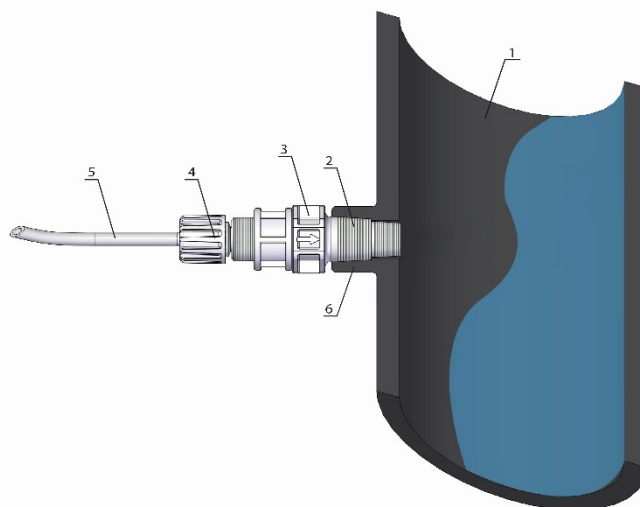

- 1 - Plant being treated
- 2 - Conical connection 3/8" – 1/2" BSP
- 3 - Injection valve
- 4 - Hose ring nut
- 5 - Discharge pump hose
- 6 - PTFE sealing type

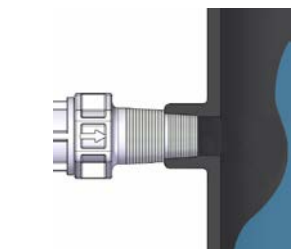

Conical connection 3/8" BSP

Fig. 7 - Injection valve mounting

Accessories



LISH

Supplied with the pump are includes the following articles:

- n.1 flexible transparent PVC clear suction hose, length 13 ft
- n.1 polyethylene semi-rigid white discharge hose, length 6 ½ ft
- n. ½" - 3/8" BSP injection valve
- n.1 foot filter
- n.1 instruction manual

OPERATING INSTRUCTIONS

eMP PUMP

Proportional metering pump. The pump doses proportionally to a flow meter pulse from 1 to 40 times, adjustable by means of the knob (8). You can choose two different types of water meter: 1 pulse every 10 gals or 1 pulse every 1 gal. When a 1:1 water meter is selected the pump waits 10 inputs before starts to dose.

Commands

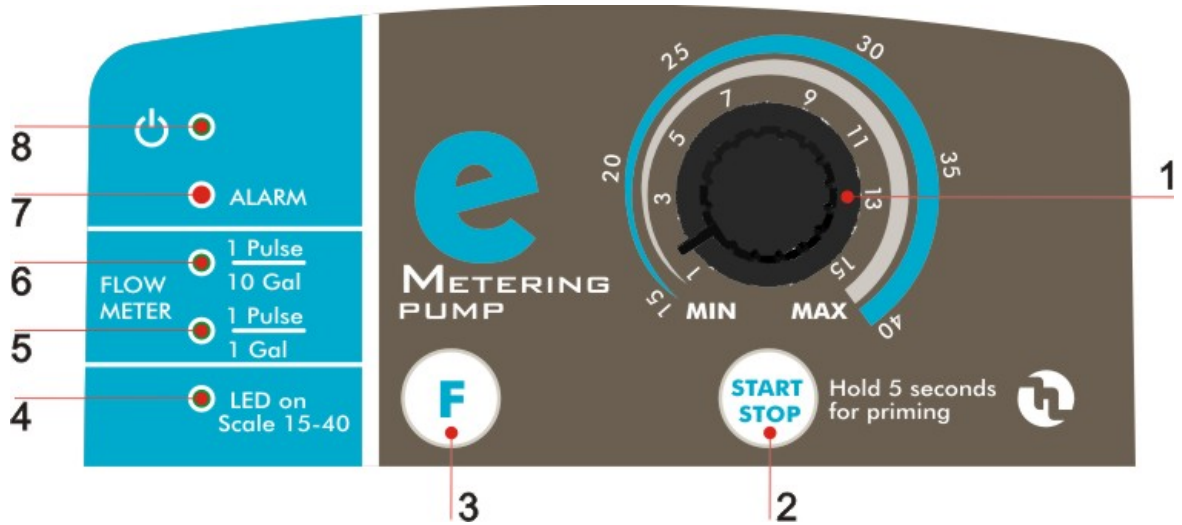



Fig.8 - Commands panel

1	Double scale adjustment knob
2	START/STOP button. Hold 5 secs for priming from stand-by mode.
3	Button function selection: selection flow meter, 1 pulse per 10 GAL, 1 pulse per 1 GAL, priming, adjustment proportional scale (1-15 or 15-40)
4	Led ON, scale 15-40 is active. Led OFF, scale 1-15 is active
5	1 Pulse per Gallon "green" LED
6	1 Pulse per 10 Gallons "green" LED
7	Alarm
8	STAND BY mode (green LED flashing), operation mode (red LED flashing)

Commands description

- 
- START/STOP button controls the activation and deactivation of the pump. Under STAND-BY mode (STOP) the LED (7) stays fixed with RED light up. Hold 5 seconds for priming, only under stand-by mode.
 - LED (7) signals the injections of the pump, "red" LED flashing, the pump operates. When the pump waits for water meter pulse the LED (7) stays fixed with light green up
 - F button to change the proportional scale (1-15 / 15 – 40), its operates only under RUN mode.

- d) F button to flow meter setting to LED (4) or LED (5). It operates only under STAND-BY mode. When you change between different operating mode, the pump starts to dosage without wait for 10 flow meter pulses. After then the pump will adjust the frequency according to the next inputs.
- e) LED (5) lights up green: the pump doses N injections per 1 flow meter pulse.
- f) LED (4) lights up green: the pump doses N injections per 10 flow meter pulses.
- g) ALARM: the pump is predisposed for level alarm (see section). The pump stops dosing and the LED (7) lights up red colour;
- h) Adjustment knob (8). You can select the proportional N multiplier (1 or 10 flow meter pulses x N pump injection). You must confirm setting by pressing at least two times START / STOP button. When you turn knob, only in stand by mode, RED led flashes at the change of the N value. One blink corresponds to increase or decrease of 1.
- i) UNDER-LOAD (see section), the pump stops dosing and the green LED lights up;
- j) OVER-LOAD (see section), the pump stops dosing and the red LED lights up;

UNDER-LOAD and OVER-LOAD functions

The innovative HRS technology has allowed to create a range of metering pumps capable of detecting pressure changes within the plant or malfunctions associated with these changes. The pump is able to provide you with useful information about the status operation. This is possible through two types of signals.

a) UNDER-LOAD: where, in normal operation, the pump is missing the fluid, in addition to the normal lack of additive in the tank, could be caused by problems on the suction line: filter clogged or damaged valves, the pump is placed in a state of UNDER LOAD . This condition is indicated by the LED green lights up (6) and the pump stops after about 10 injections.

b) OVER-LOAD: The pump, during normal operation, performs a real-time control on the pressure conditions inside the plant to be treated. If this pressure exceeds the maximum allowed (factory default), the pc-board of the pump reacts lighting up the red LED (6) and stop the dosing after about 10 injections. Under particular conditions of pressure could occur the OVER-LOAD alarm even with air presence in the pump body. We recommend that you take action to check the pump.

The OVER-LOAD and UNDER-LOAD functions can be enabled and disabled by pressing and holding (for about 5 seconds) F button (2). A triple blink of the red LED (6) indicates that the function has been enable, while a triple blink of the same LED with green color (6) indicates that the function has been disabled. During this steps the pump stop dosing and start after the function has been enabled / disabled. **OVERLOAD and UNDERLOAD functions are enabled by factory default.**

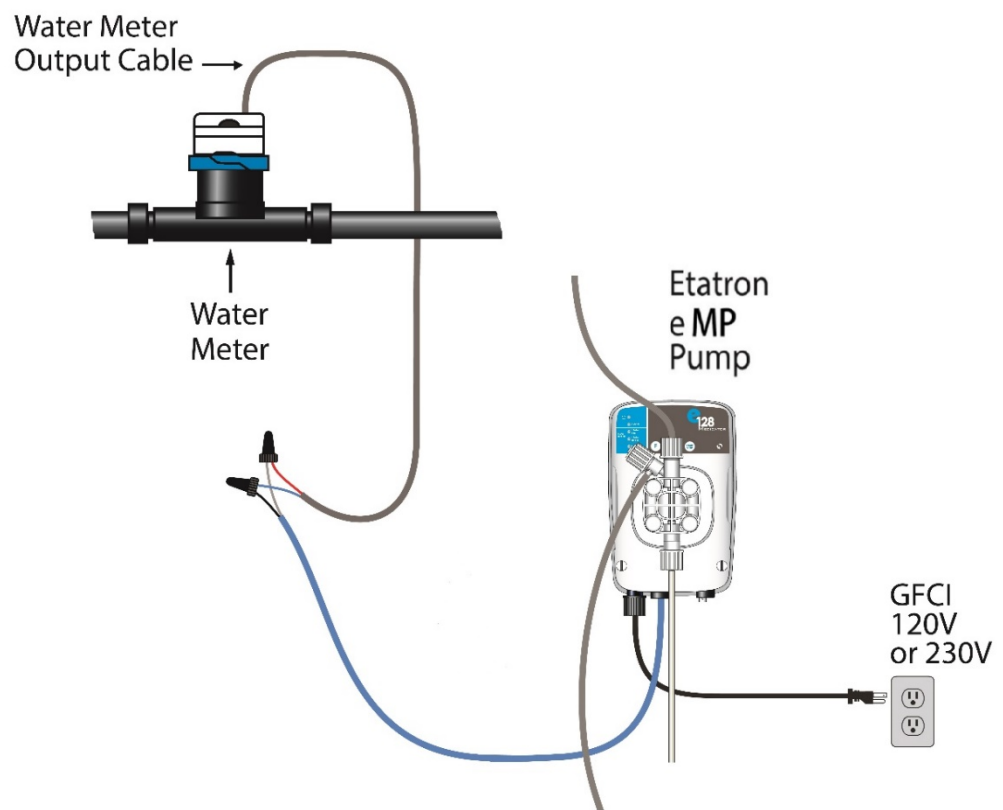

Fig. 9 – Water meter connections

Ordinary



An Ordinary and accurate maintenance with a programmed check, guarantee the preservation over time and the proper functioning of the systems. Therefore, we recommend that the user follow our advice and maintenance of a service contract and assistance programmed with one of our Technical Support Centre.

Check at least every 6 months functioning of the pump. In case of intensive use of the metering pump, you should increase the frequency of these controls.

Check inside the pump head the presence of deposits, in this case they can be removed by disassembling the piece and washing it with water. If the deposits are difficult to remove, it is recommended to dip the part in an aqueous solution of hydrochloric acid, then rinse it with water.

Check regularly the seals of valves, diaphragm and any other seals, because as part of normal wear and tear may be subject to deterioration.

To replace the diaphragm, remove the 4 screws, unscrew the membrane and replace the O-Ring, reassemble all pieces making sure to tighten the screws in a balanced way (screw alternately cross respecting the prescription of torque).

Check and replace the sealing of the injection valve as it may be subject to deterioration due to wear and serving as a check valve in the pump may cause a return of the product dosed.



Warning: When removing the pump from the plant act carefully removing the tube from the discharge nipple, as it could leak out the additive from the tube. Again, if the casing is in contact with the additive must be cleaned.

Warning: when the power supply is deactivated the pump may emit one or more pulses, so before you disconnect the tubes make sure that the pump is turned off completely.



Extraordinary

All components of our supplies are chosen and tested according to strict principles of selection, and then provide, for a long time, reliability and functionality in our devices.

Mechanical Faults

As the system is quite robust there are no apparent mechanical problems. Occasionally there might be a loss of liquid from the nipple because the tube nut has loosened, or more simply the discharge tubing has broken. Very rarely there may be losses caused by the breakage of the diaphragm, or by the diaphragm seals in which case they have to be replaced by disassembling the four screws of the pump head - appendix 1), when re-mounting the pump head ensure that the screws are replaced properly, along with "O" ring. After repair, the metering pump will need to be cleaned of additive residues which can damage the pump casing.

THE METERING PUMP GIVES PULSES BUT THE ADDITIVE IS NOT INJECTED

Dismount the suction and discharge valves, clean them and replace, see position (appendix 1). Should the valves be swollen, check valves material against our chemical resistance compatibility chart and fit correct valves..

- Check the clogging of the foot filter;
- Check the injection valve.

Electrical Faults

ALL LEDS OFF, THE PUMP DOES NOT PULSE.

Check power supply (socket, plug, power switch ON), if the pump doesn't work contact manufacturer Customer Service, Dealer or Distributor.



Routine

Thorough routine maintenance, together with a scheduled inspection, ensures preservation and good functioning of the systems over time.

We therefore recommend you follow our routine maintenance advice and enter into a programmed service and assistance contract with a trusted Technical Support Center.

Please also note that the timing of the maintenance listed below, are to be considered solely for a theoretic purpose, as they shall vary depending on several factors: type of system, type of product metered, the environment where the pump is installed, etc.

Before performing any maintenance or cleaning operations on the metering pump, you must:

- 1) Check that is disconnected from the electric power supply (remove the plug from its electric socket).
- 2) Eliminate any remaining pressure from the pump head and from the flow pipe in an appropriate manner (very carefully).

In the event of leakage from the pump hydraulic system (breakage of a valve or a pipe), it must be stopped and the flow pipe must be depressurised taking all necessary precautions (gloves, goggles, protective clothing).



ROUTINE MAINTENANCE TABLE				
		Time interval		
		2 weeks	1 month	2 months
Pump operation			✓	
Pump and valve body cleaning			✓	
Injection valve cleaning			✓	
Bottom filter cleaning			✓	
Inspection of intake and flow pipes to identify obstructions and/or punctures				✓

TROUBLESHOOTING



Given the sturdiness of the system, mechanical failures do not occur. Sometimes liquid may leak from a loose connection or pipe clamp, or simply due to the rupture of the flow pipe. Leaks are rarely caused by the rupture of the diaphragm or by the wear of the membrane gasket. In this case these components must be replaced by removing the four screws of the pump body, remounting the screws and clamping them evenly. When the leak has been eliminated, any residues of additive must be removed from the metering pump, as by stagnating it would corrode the pump casing.

Any intervention or repair within the equipment must be carried out by qualified and authorised personnel.



In the event of maintenance and/or technical work, always make sure that the pump is disconnected from the electrical mains and that you are wearing protective clothing and equipment (gloves and safety goggles).

FAULT	SOLUTION
The pump is not metering	<ul style="list-style-type: none"> • Check valve mounted incorrectly or deteriorated: mount it properly or replace it by following the routine maintenance advice; • Membrane deteriorated, replace it; • Magnet fuse blown, replace it (check magnet resistance) • Electromagnet blown, replace it
The electronic part does not transmit pulses to the magnet	Electronic board blown due to overvoltage, no earthing, etc.: replace the board
The pump runs irregularly	Check that the value of the power supply voltage is within the specified limits.
The pump does not run in the functions: 1 Pulse per gallon and 1 pulse per 10 gallons), (with meter)	Check the connection between the meter output and the corresponding connector on the pump.
There is an infiltration	<p>a) Through the head gasket Undo the four head screws and make sure that the o-ring of the pump body is in good condition and that the diaphragm is screwed on correctly, otherwise replace them. Also make sure that the infiltration did not damage the board or the magnet.</p> <p>b) Through the control panel Observe the board and check the state of preservation of the electrical components and printed circuit tracks. Check the electrical resistance of the electromagnet. In the event that one of the two components is damaged, replace it. Make sure that all the components that secure the flow pipe are mounted properly and that they are not damaged. Replace also serigraphy which enabled the infiltration.</p>
The pump runs but does not draw the liquid	Remove the suction and discharge valves, clean them and replace them in the same position. Check the state of clogging of the filter and the injection valve

APPENDIX 1 – PUMP DRAWINGS

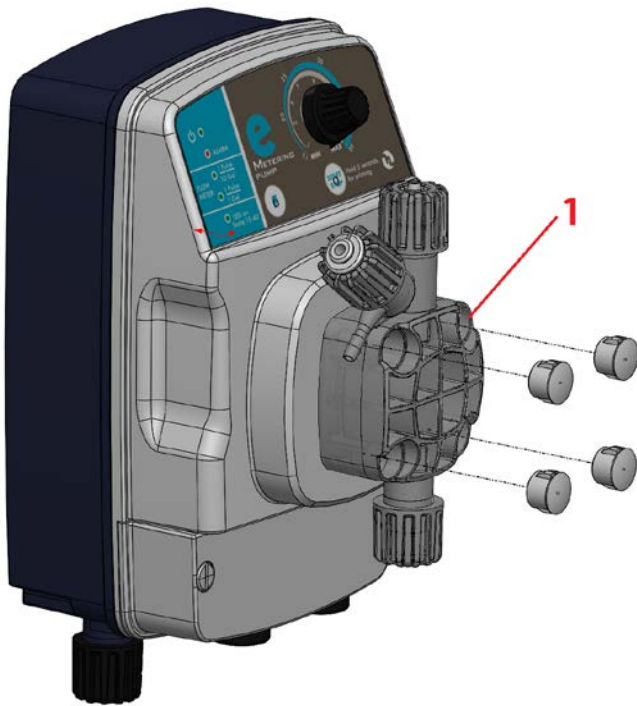

1. pump head screws (x4)

to tighten the four screws use a dynamometer screwdriver set to a tightening torque of 180÷200 Nxcm using a hexagonal insert of 3 mm

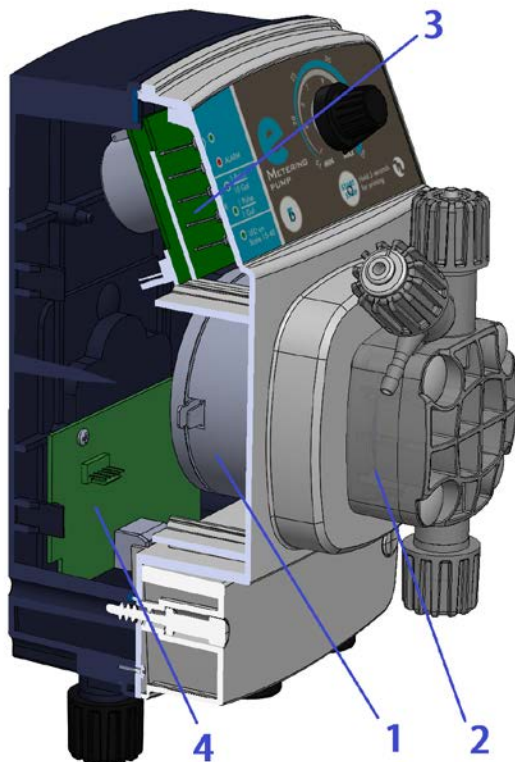

- 1 – ELECTROMAGNET

Item code: SEM8406052

- 2 – PUMP HEAD

Item code: SCP8105471

- 3 – PC BOARD

Item code: RPB0022231

- 4 – PC BOARD for flow meter

Item code: RPB0022401

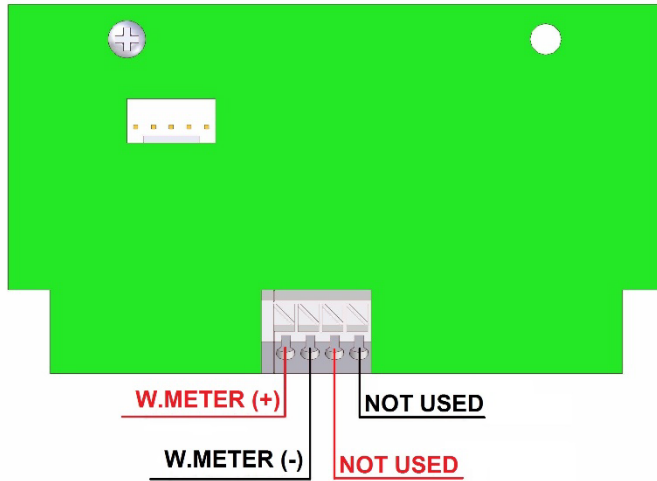

TERMINAL BOARD

Item code: RPB0022401

APPENDIX 2 – EXPLODED VIEWS

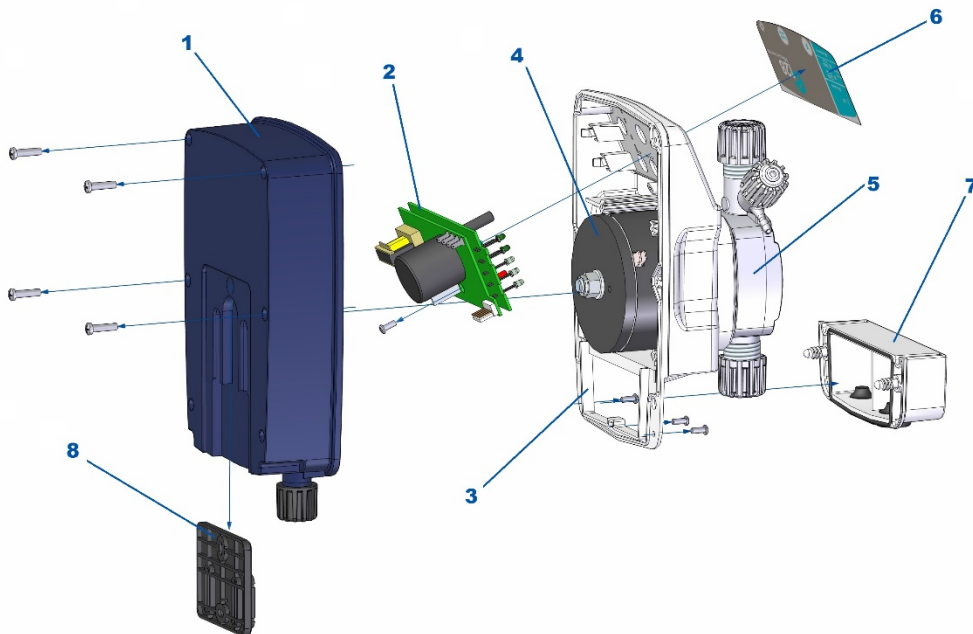

- | | |
|---------------------|-----------------------|
| 1. PLASTIC CASING | item code: DCE0010102 |
| 2. PC-BOARD | item code: RPB0022231 |
| 3. HYDRAULIC CASING | item code: DCA0003001 |
| 4. ELECTROMAGNET | item code: SEM8406052 |
| 5. PUMP HEAD | item code: SCP8105471 |
| 6. PANEL | item code: GSG0022312 |
| 7. CONNECTOR COVER | item code: SCE0010202 |
| 8. PLASTIC BRACKET | item code: DSA0001401 |

TUBES INSTALLATION

- Take the cap off from the top of the tube nut (Item 1).
- Insert the tube through the tube nut (Item 1), then through the tube bush (Item 2) and then insert the conical part of the tube nozzle (Item 3) **inside the end of the tubing**.
- Place all components on the nipple of the pump head (Item 5) making sure that the O-ring (Item 4) is fitted into its seat. Lock everything with the tube nut (Item 1).

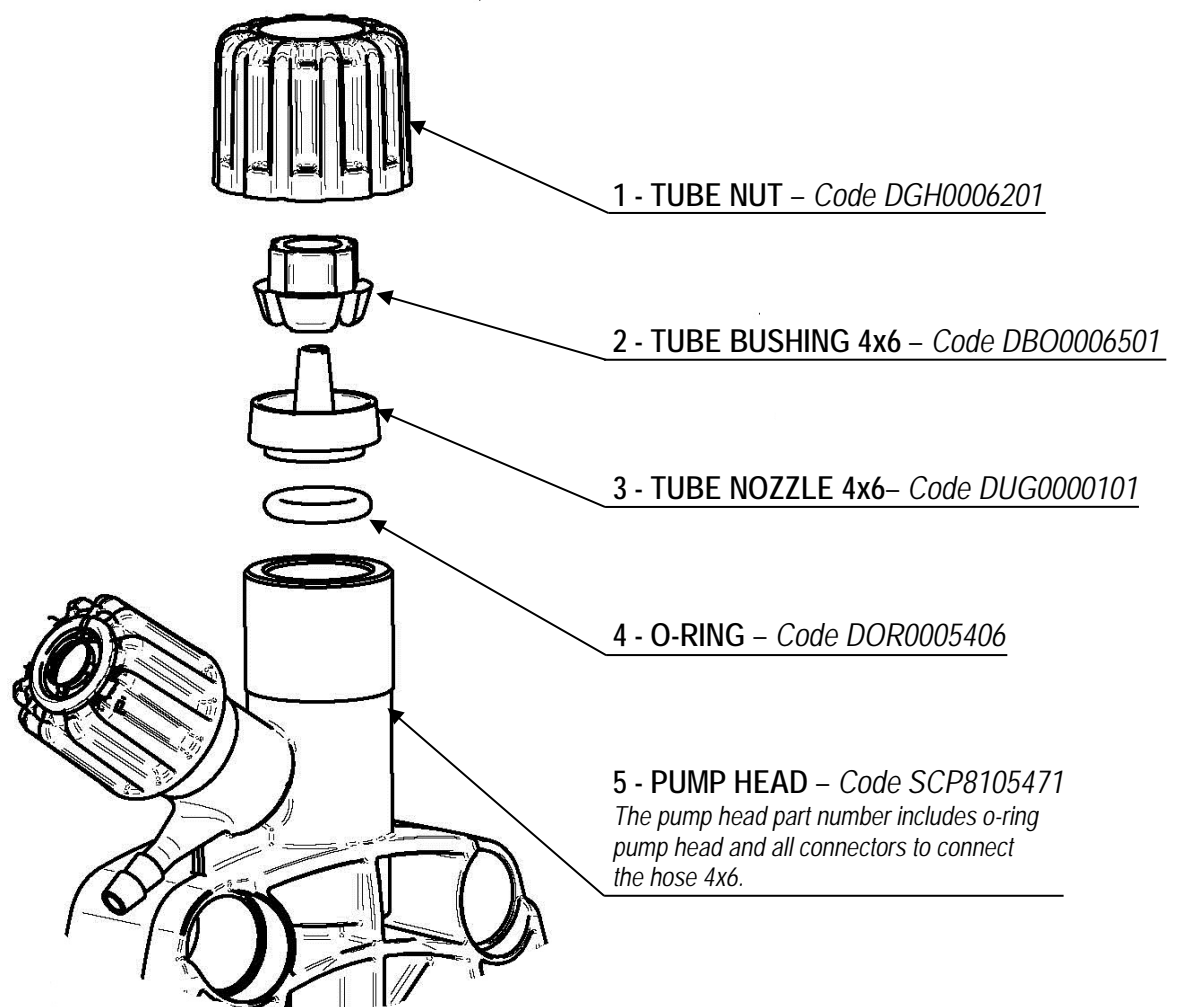

3/8" - 1/2" INJECTION VALVE

Comprehensive view and features

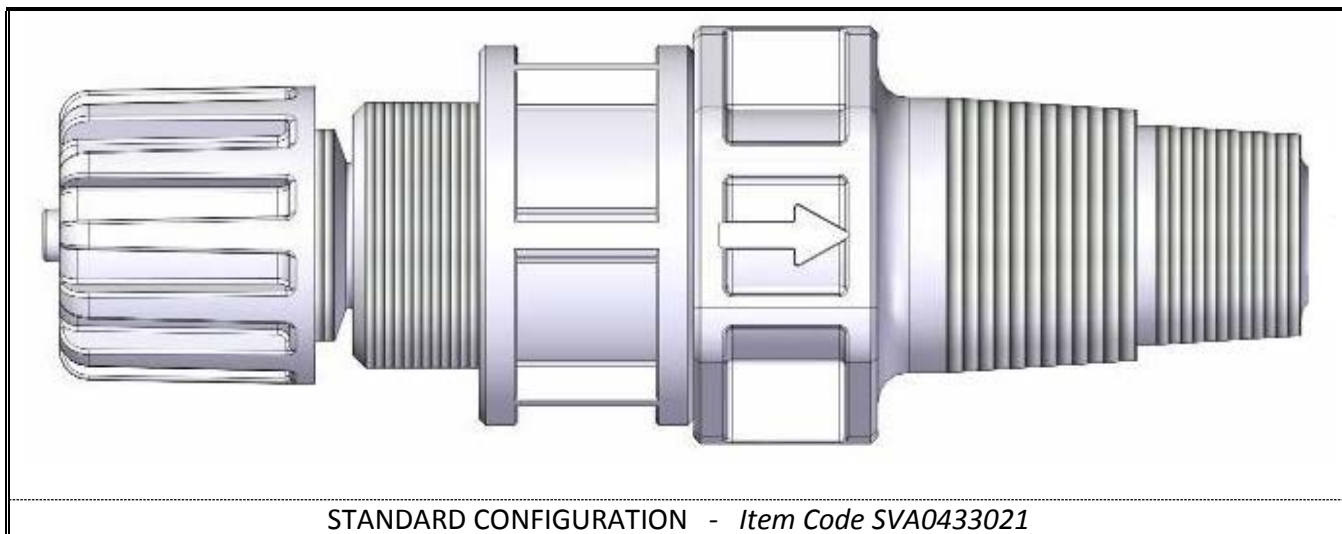

Overall dimensions and characteristics

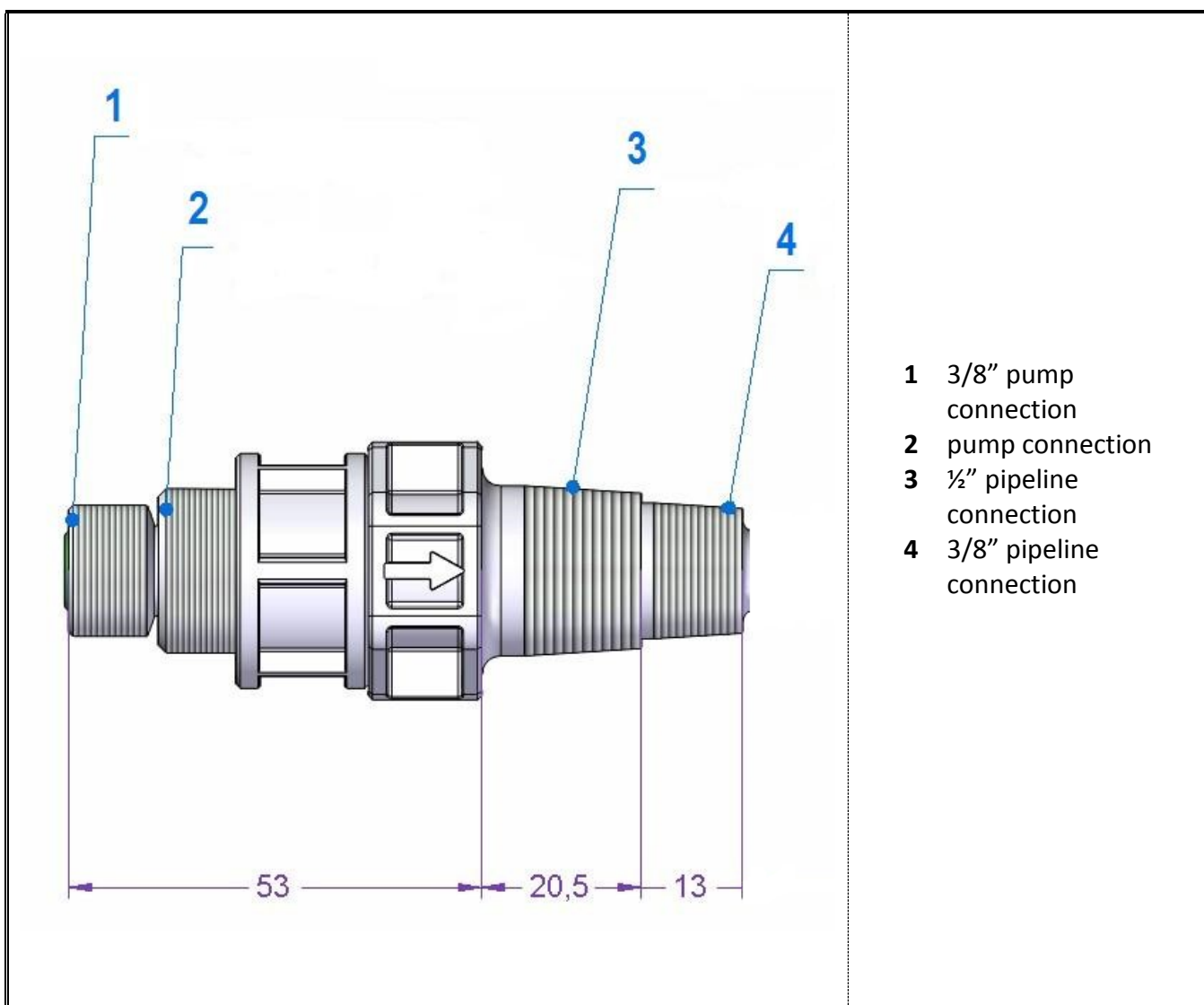



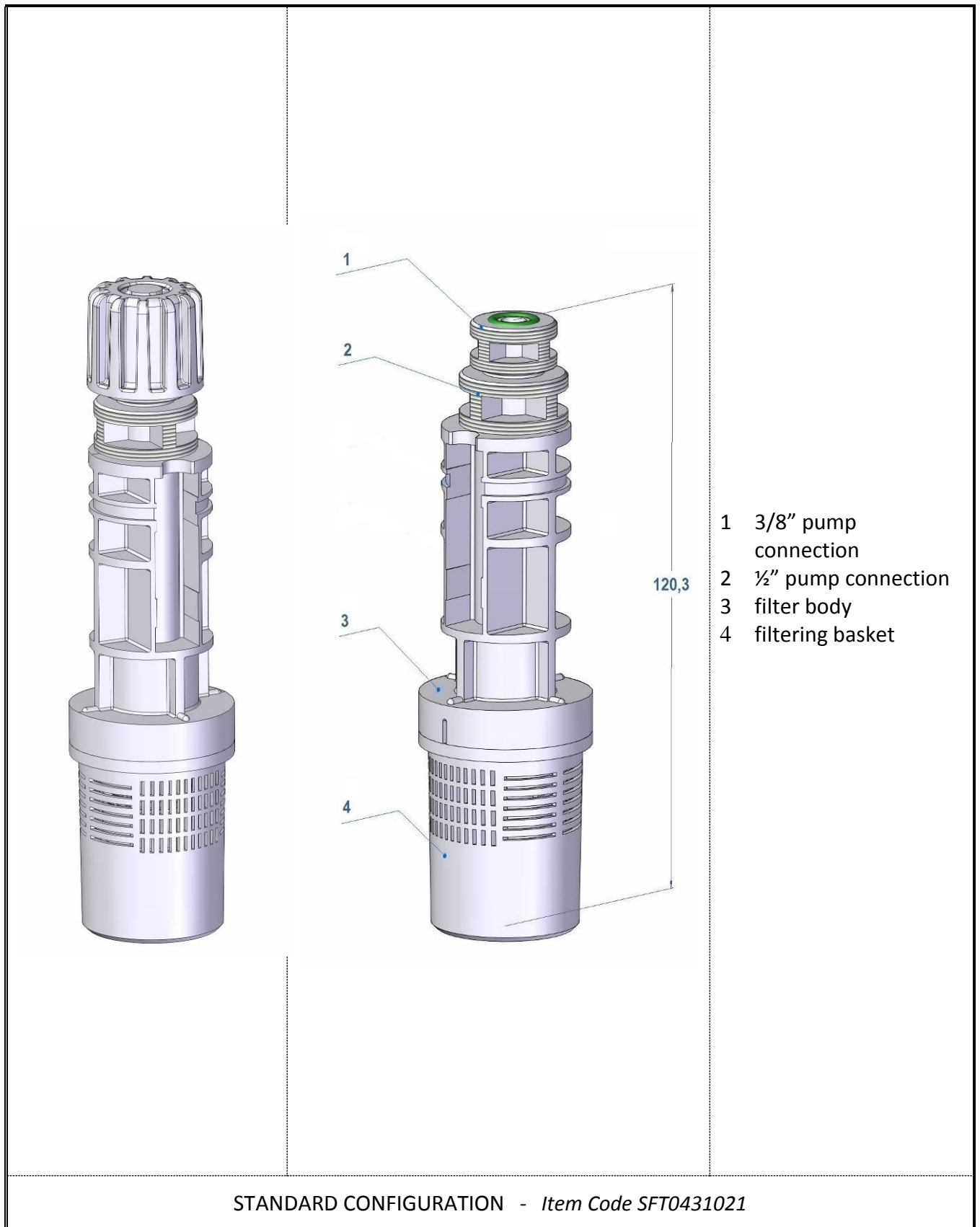

3/8" - 1/2" FOOT VALVE FILTER

Comprehensive view and features



Kit contents

REF.	DESCRIPTION	ITEM CODE	Q.TY
	FILTER	SFT0431021	1
	4x6 TUBE BUSH	DBO0006501	1
	4x6 TUBE NOZZLE	DUG0000101	1
	NIPPLE 3/8"	DGH0006201	1

Exploded view

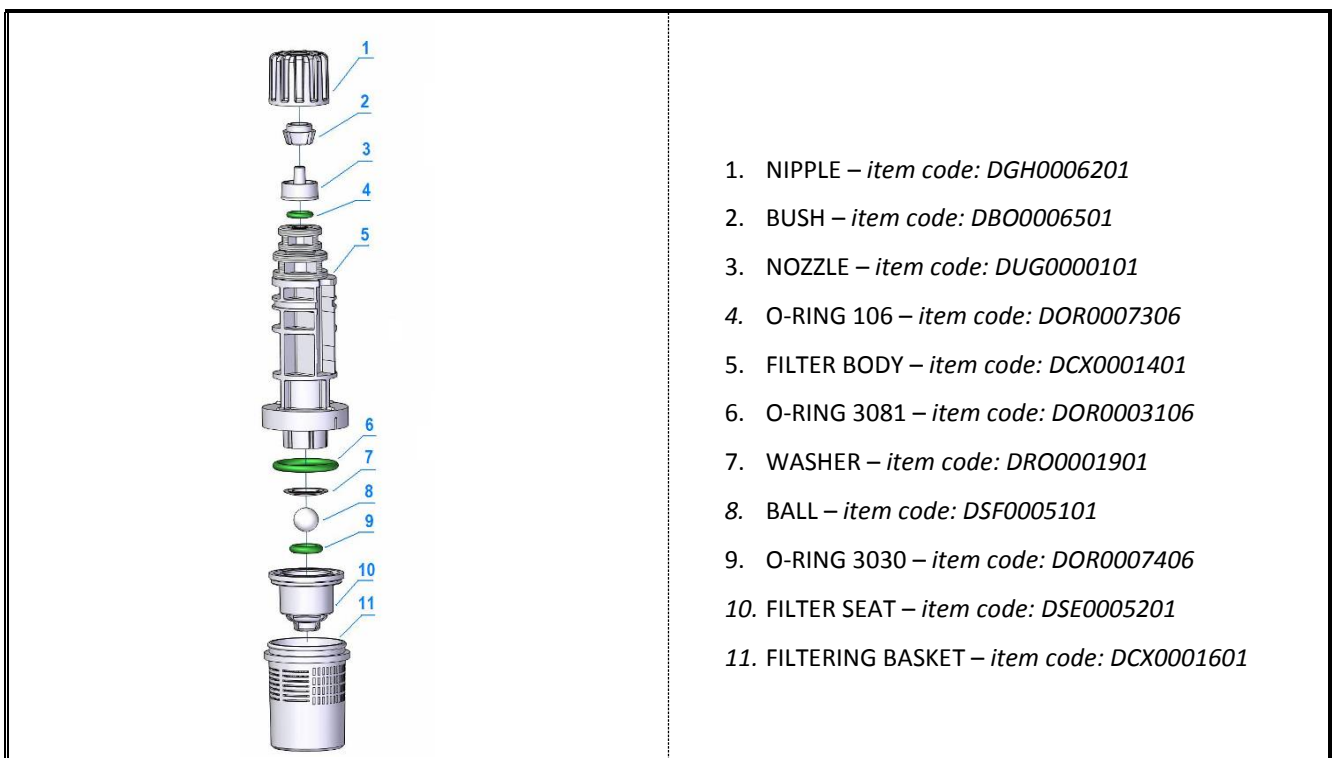

ETATRON AMERICA

Dilution Solutions Inc
2090 Sunnydale Blvd
Clearwater FL 33765
Telephone: 727-451-1198
FAX: 727-451-1197

WDMU00215ML1B (09 - 2019)